

# SAFETY EQUIPMENTS



# MANIK

ENGINEERING PVT. LTD.

Interior Solutions  
Customizing if volumes are Large



# OUR PRODUCTS



**Guard Rails (Pg. 2-4)**

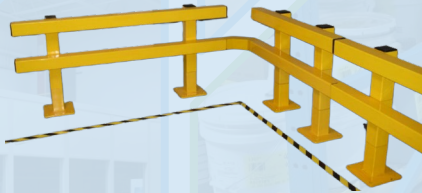

**Safety Barrier (Pg. 5-6)**

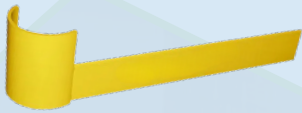

**Rack Protector (Pg.8-10)**

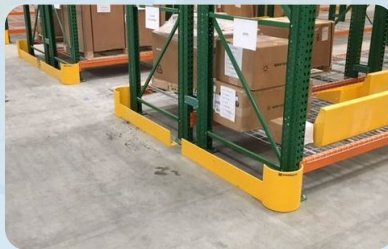

**(Pg.11-13)**  
**Space Saving Rack Protectors**



**(Pg.20)**

**Steel Bolt On Protector**



**Post Protector (Pg.19)**



**(Pg.21-23)**  
**Corner Column Protector**

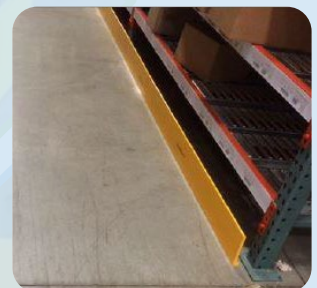

**(Pg.14)**

**Steel Guide Angle**



**Shallow Profile Upright Post Protector (Pg.24-25)**

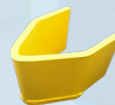

**(Pg.1-3)**  
**V-nose Guard Post Protector**

# GUARD RAIL

Warehouse guard railing systems are an essential safety component within your facility. Guard rail provides a physical and visual barrier to protect from forklift and powered vehicle accidents. The rail system can be installed along pedestrian walkways to keep your employees safe.

Guard rail separates work areas from forklift driving lanes. This reduces the chance of worker accidents and equipment damage. Places you should install guarding includes in-plant offices, shipping departments, around machinery, walkways, and at the ends of pallet racking.



## FEATURES

- Tested to withstand 4500 kg at 4 mph
- Constructed with high-quality ASTM A1011 steel
- Powder-coated yellow for maximum visibility and durability
- Rail lengths from 610 mm to 3050 mm long
- Columns are 120 mm × 120 mm steel square tube mounted on a 254 mm × 254 mm base plate
- Designed for faster installation to cut down on labor costs
- Single (457 mm) or double high (1092 mm) rail systems
- Bolted rail or drop in rail styles
- Universal 4 way mounting posts eliminate the need for “end” or “line” posts
- All anchors and hardware/caps are included



# GUARD RAIL SPECIFICATIONS

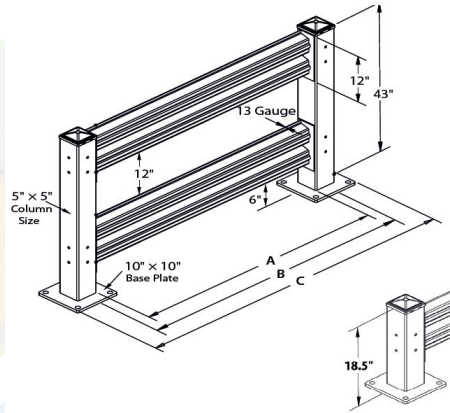

Part Number	A Rail Length (mm)	B Center to Center of Columns (mm)	C Outside to Outside of Base Plates (mm)	Weight (kg)
GR-10	2920	3048	3302	24
GR-9	2616	2743	2997	21
GR-8	2311	2438	2692	20
GR-7	2006	2134	2388	17
GR-6	1702	1829	2083	15
GR-5	1397	1524	1778	13
GR-4	1092	1219	1473	11
GR-3	787	914	1168	9
GR-2	483	610	864	6

## POST STYLES

### Column Options

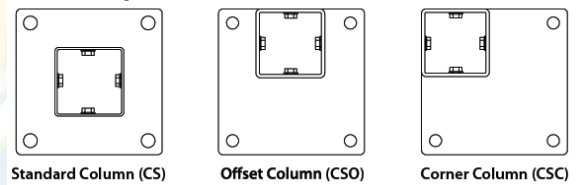

Part	Column Height (mm)	Description	Baseplate Location	Weight (kg)
CS-1	470	Single rail post	Centered	14
CSO-1	470	Single rail post	Offset to one side	14
CSC-1	470	Single rail post	Set to Corner of post	14
CS-2	1092	Double rail post	Centered	24
CSO-2	1092	Double rail post	Offset to one side	24
CSC-2	1092	Double rail post	Set to corner of post	24
SG-3654A	n/a	Pedestrian Swing Gate adjustable, 92 – 137 mm	n/a	17



# AREAS TO INSTALL FORKLIFT GUARD RAILS

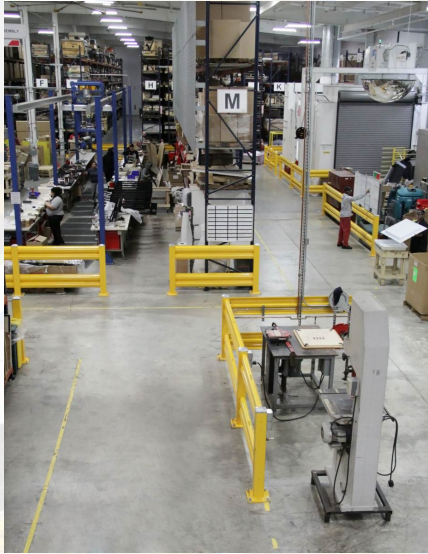

Lift-Out Adapter



Pedestrian Swing Gate

Single High  
Or Double  
High Guard  
Rail Post

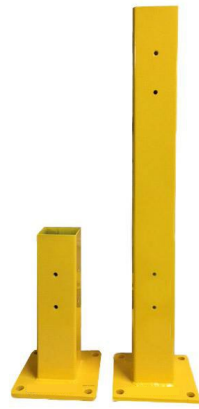

45 Deg. Angle  
Adapter

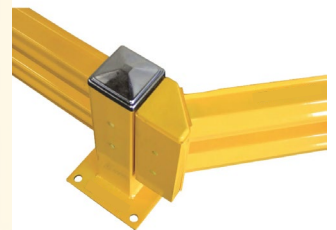

Hardware And Cap  
Included In Every  
Order

- Around in plant offices and workstations
- Along pedestrian walkways
- To protect sensitive machines
- At the end of warehouse rack aisles
- Adjacent to conveyor lines
- Around mezzanines
- Shipping and packing areas

# SAFETY BARRIER

Build-A Rail Guard Rails are heavy duty, customizable and easily assembled to protect property from damage due to forklift impact. .

Build rail systems one, two or three rails high by just stacking rail units one on top of the other.

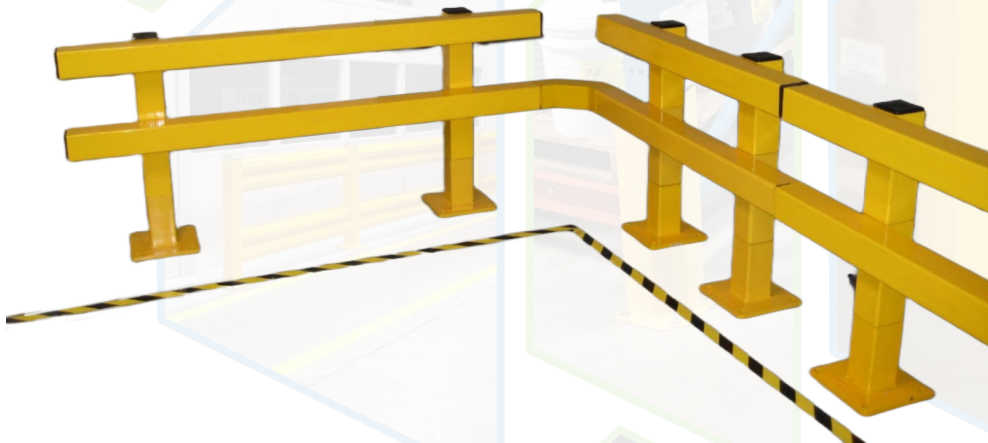

## FEATURES

- Barriers are rated to withstand an impact of 4500 kg at 4 mph to keep valuable equipment safe from forklift traffic
- Rail sections are constructed of sturdy 5/ 813 mm wall, 102 mm x 102mm steel tube
- Base units are constructed of 5/ 813 mm wall, 102 mm x 102 mm steel tube welded to 13 mm thick 254 mm x 254 mm base plates
- Highly visible, yellow powder coat painted steel units provide a visible, durable, and attractive finish
- Black plastic end caps close ends and tops giving a finished look
- Stackable and side-by-side joinable units provide flexibility in guard rail system design
- Straight sections and 90 degree turns are easily accomplished using straight and corner couplers
- Build-A-Rail sections are installed correctly by following the easy to use instructions



# SAFETY BARRIER SPECIFICATIONS

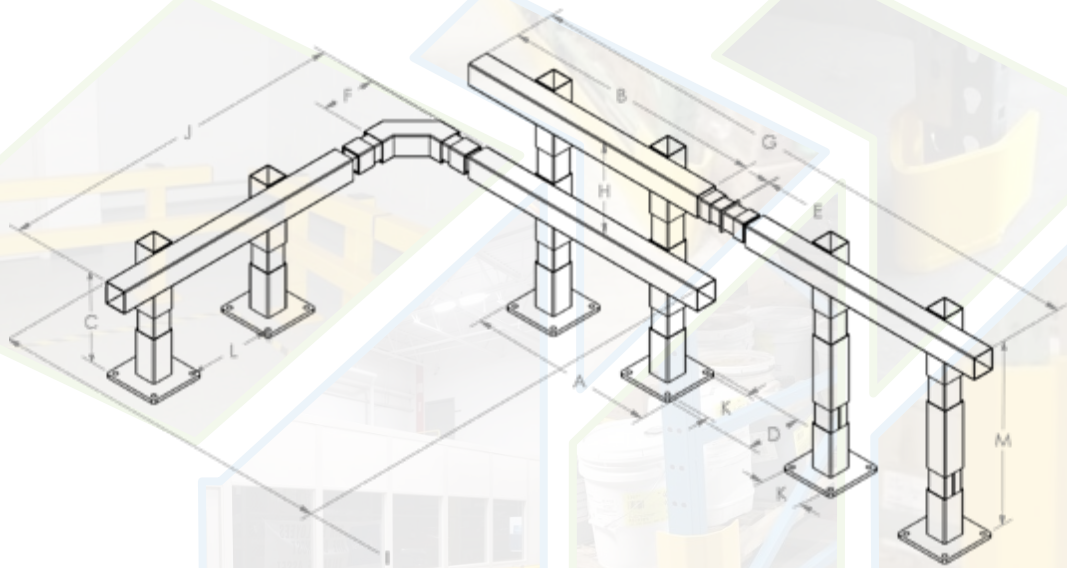

1. Measure overall length of area to be protected.
2. Is there a protruding object or other unusual configuration to measure? (i.e. in-plant offices or corners)
3. Is this a single or double rail application? (the height to protect is the key factor)
4. Place protection equipment a minimum of 305 mm in front of what you're protecting to achieve proper installation.

Part	A Base to Base (mm)	B Rail Length (mm)	C Rail Height (mm)	D Base Length/ Width (mm)	E Visible Collar Length (mm)	F Corner Collar Visible Width (mm)	G Length of 2 Collared Rails (mm)
BR - 4	864	1219	508	254	25	254	1245 + Length of Additional Rail
BR - 6	1473	1829	508	254	25	254	1854 + Length of Additional Rail
BR - 8	2083	2438	508	254	25	254	2464 + Length of Additional Rail
BR - 10	2692	3048	508	254	25	254	3073 + Length of Additional Rail

H Height of add'l stacked rails (mm)	I Width of 2 Corner Collared Rails (mm)	J Length of 2 Corner Collared BAR (mm)	K Dist. of Holes on Base (mm)	L Dist. of holes Base-to-Base (mm)	M Height of Rail w/ Leg Ext. (mm)
305	1473	305 + Length of Additional Rail	203	406	813
305	2083	305 + Length of Additional Rail	203	1016	813
305	2692	305 + Length of Additional Rail	203	1626	813
305	3302	305 + Length of Additional Rail	203	2235	813

## Build-A-Rail Selection Tips

Once you have measured the overall length of the area to be protected, divide the length needed by the length of rails. It is recommended to use as many long rails as possible while still protecting the designated area. The reason for using the longest rails, in equal lengths, is both for aesthetic and economic considerations. The longer the rail, the more coverage you receive while using fewer bases. This gives you maximum protection for the most economical price. Standard rails are 1219 mm to 3048 mm long in 610 mm increments. Components are sold individually.



# AREAS TO INSTALL SAFETY BARRIER



Stackable Units

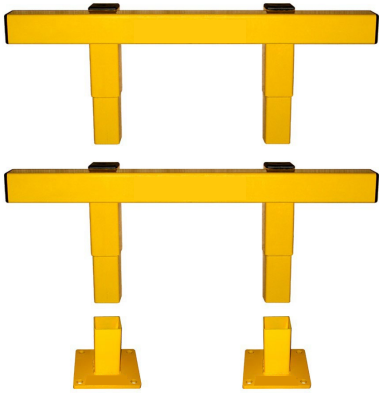

Base Unit



Various lengths 1219 mm – 3048 mm length



Collar Connector

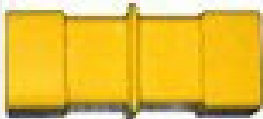

Corner Collar Connector

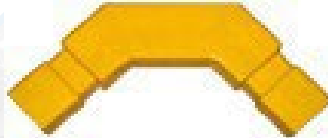

Side-by-Side Joinable Units

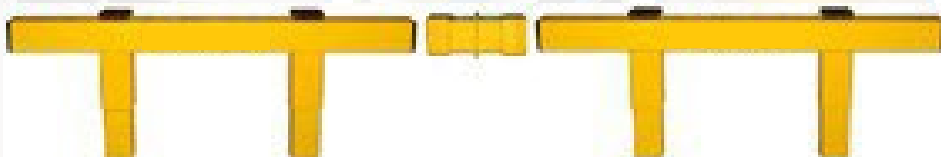

- Office areas within a plant or factory floor
- Around production equipment
- Pedestrian walkways
- End-of-Rack Aisles





# RACK PROTECTORS

Rack Protectors protect uprights from powered and non-powered material handling equipment impacts. They are an inexpensive, yet effective tool to help avoid dangerous and costly racking damage.

Rack protectors will extend the life of your racking system, as well as increase safety for your workers.



## FEATURES

- Available in Heavy and Standard Duty to suit your needs and budget
- Work with both standard and seismic baseplates
- Steel floor angles attach securely to floor with 4 or 5 wedge anchors depending on length (sold separately)
- Powder coated in yellow for high visibility
- Custom sizes available upon request



# RACK PROTECTORS SPECIFICATIONS

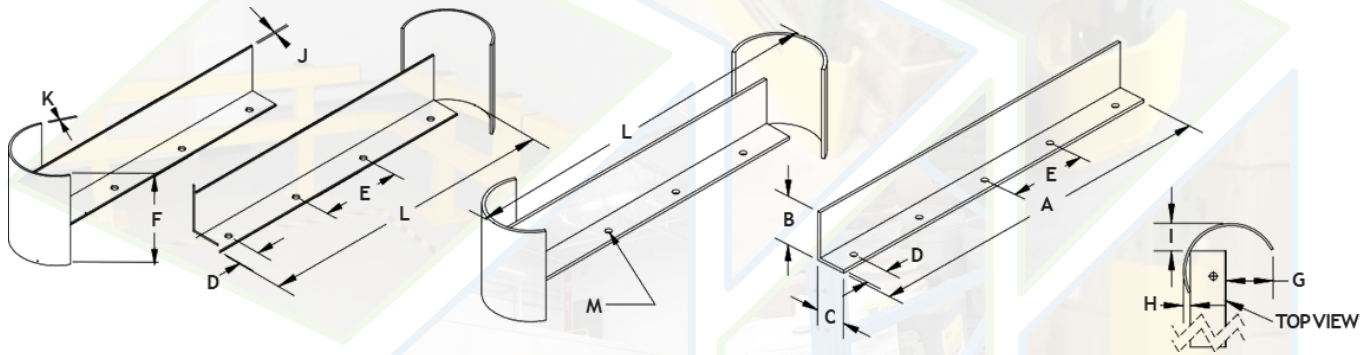

Part	A	B	C	D	E	F	G	H	I	J	K	L	M		
	Length of Extension (mm)	Height of Leg (mm)	Width of Leg (mm)	End to Hole (mm)	Hole to Hole (mm)	Height of Curve (mm)	Extension to Back of Curve (mm)	Extension to Front of Curve (mm)	Extension to Curve side (mm)	Extension Thickness (mm)	Curve Thickness (mm)	Outside Overall Length (mm)	Hole Diameter (mm)	Number of Holes	Curve Location
RP-42LH-MD	1092	165	102	147	267	305	114	25	76	6	6	1168	22	4	Left
RP-42RH-MD	1092	165	102	147	267	305	114	25	76	6	6	1168	22	4	Right
RP-48LH-MD	1207	165	102	71	267	305	114	25	76	6	6	1283	22	5	Left
RP-48RH-MD	1207	165	102	71	267	305	114	25	76	6	6	1283	22	5	Right
RP-42LH-HD	1092	165	102	147	267	305	127	25	76	10	10	1168	22	4	Left
RP-42RH-HD	1092	165	102	147	267	305	127	25	76	10	10	1168	22	4	Right
RP-42EX-MD	1092	165	102	147	267	N/A	N/A	N/A	N/A	10	N/A	1092	22	4	No Curve
RP-48LH-HD	1207	165	102	71	267	305	127	25	76	10	10	1283	22	5	Left
RP-48RH-HD	1207	165	102	71	267	305	127	25	76	10	10	1283	22	5	Right
RP-48EX-HD	1207	165	102	71	267	N/A	N/A	N/A	N/A	10	N/A	1092	22	5	No Curve
RP-60EX-HD	1575	165	102	122	267	N/A	N/A	N/A	N/A	10	N/A	1524	22	6	No Curve
RP-60EX-MD	1575	165	102	122	267	N/A	N/A	N/A	N/A	6	N/A	1524	22	6	No Curve
RP-42-HD	1092	165	102	147	267	305	127	25	76	10	10	1524	22	4	Both Sides
RP-48-HD	1207	165	102	71	267	305	127	25	76	10	10	1283	22	5	Both Sides
RP-42-MD	1092	165	102	147	267	305	127	25	76	6	6	1524	22	4	Both Sides
RP-48-MD	1207	165	102	71	267	305	127	25	76	6	6	1283	22	5	Both Sides

**NOTE: Use 19 mm size Wedge Anchors (not included)**

## Rack Protector Equipment Considerations

- Measure the overall length of area that is to be protected
- Is there a protruding object or other unusual configuration to measure? (i.e. going around corners)
- Is this a single or double end application? (Exposure to traffic is the key factor)
- Place protection equipment as close as possible in front of the area in need of protection while still providing an adequate barrier space to achieve proper installation.



# AREAS TO INSTALL RACK PROTECTOR

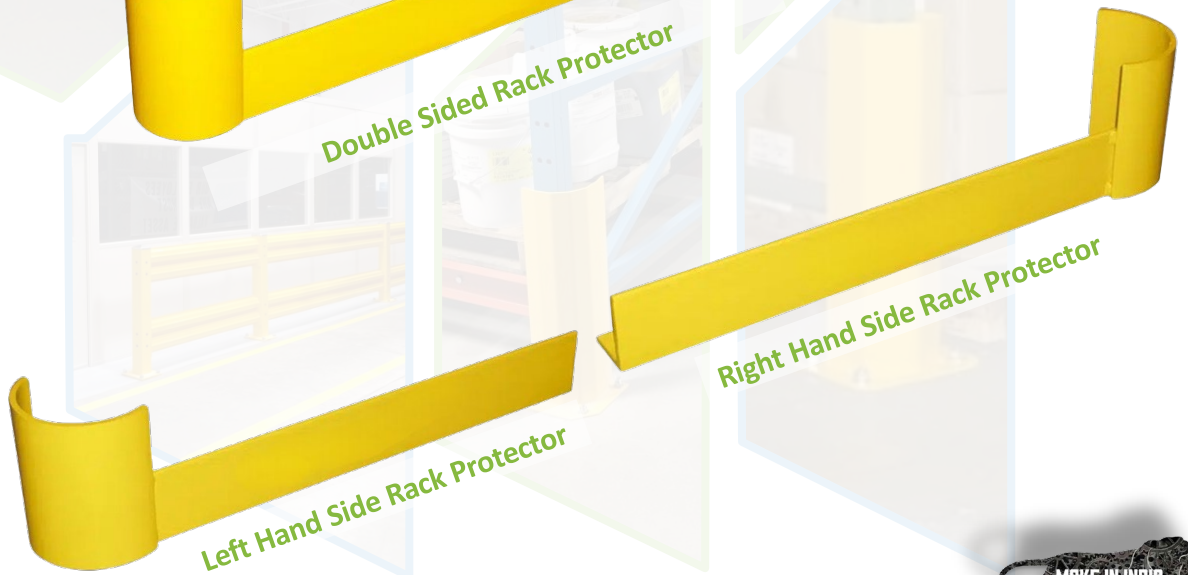
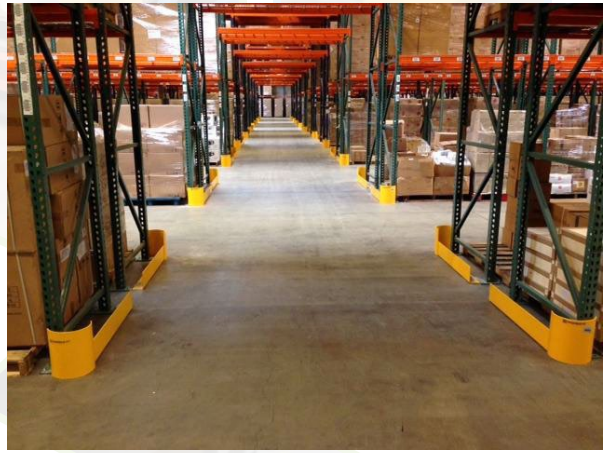
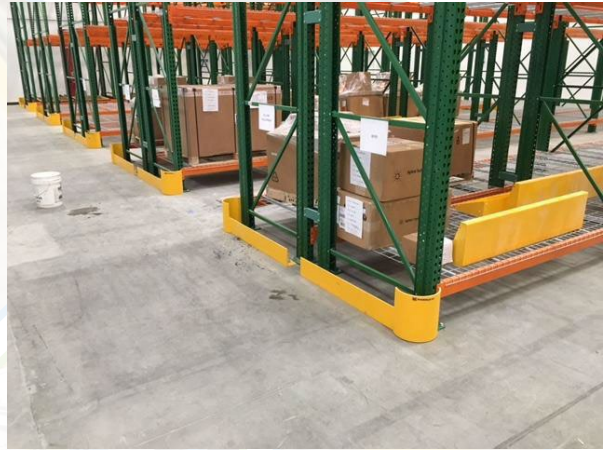

# SPACE SAVING RACK PROTECTORS

Space Saving Rack Protectors guard uprights from powered and non-powered equipment traffic in your warehouse.

Our special design allows for you to install the guard very close to the uprights, saving vital floor space while not compromising the protection value.

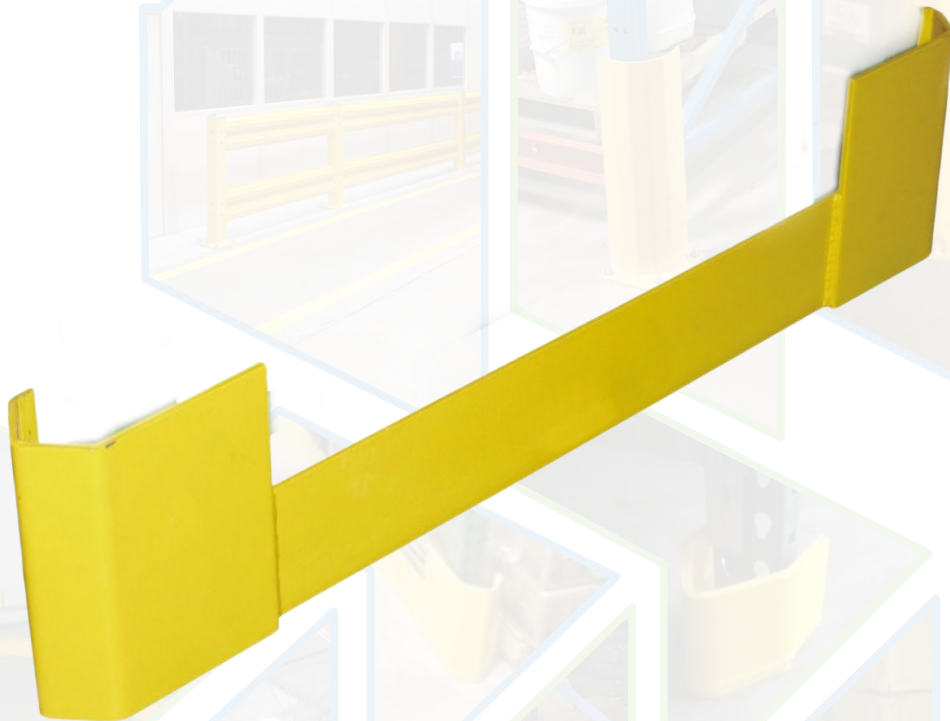

## FEATURES

- Special notched design saves vital space
- Heavy duty 10 mm steel construction
- Especially useful in narrow aisle situations and tunnels
- Steel floor angles attach securely to floor with 4 or 5 wedge anchors (sold separately)
- Powder coated in yellow for high visibility
- Narrow formed guard keeps the first pallet bay clear
- Anchor point in the nose increases holding power right at the rack upright



# SPACE SAVING RACK PROTECTORS SPECIFICATIONS

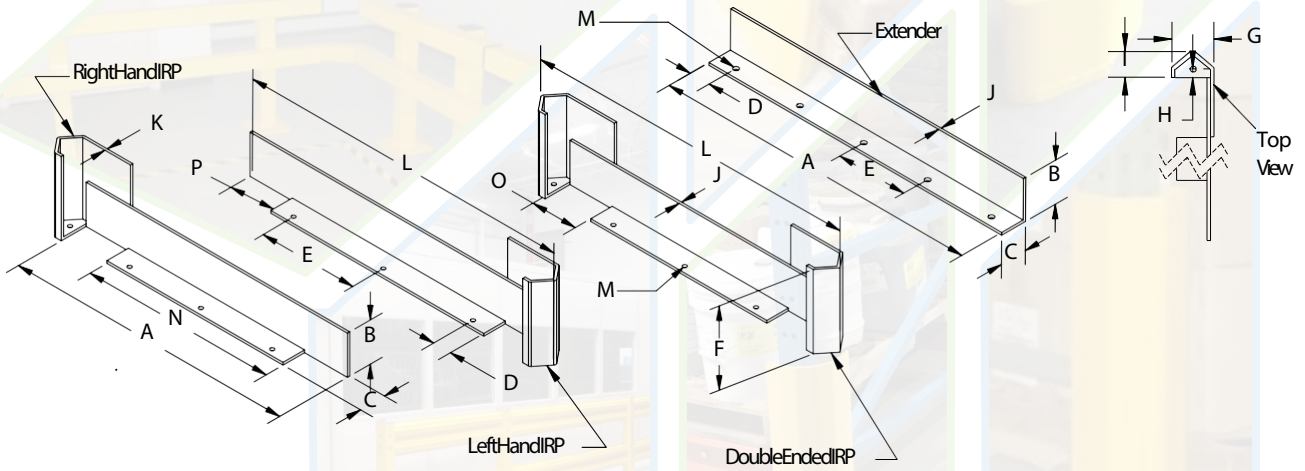

Part	A Outer Length of Extensio n (mm)	B Height of Leg (mm)	C Width of Leg (mm)	D End to Hole (mm)	E Hole to Hole (mm)	F Height of Curve (mm)	G Width of Curve (mm)	H Curve Hole to End (mm)	I Length of Curve (mm)	J Extensio n Thickne ss (mm)	K Curve Thickne ss (mm)	L Outsid e Overal l Length (mm)	M Hole Diamete r (mm)	N Inner Length of Extensio n (mm)	O Gap Lengt h Single (mm)	P Gap Lengt h Doubl e (mm)	Number of Holes	Curve Locatio n
IRP-42-HD	1092	165	102	71	297	305	127	25	76	10	10	1245	24	635	229	N/A	5	Both Sides
IRP-42LH-HD	1092	165	102	71	297	305	127	25	76	10	10	1168	24	635	N/A	229	4	Left
IRP-42RH-HD	1092	165	102	71	297	305	127	25	76	10	10	1168	24	635	N/A	229	4	Right
IRP-48-HD	1245	165	102	71	376	305	127	25	76	10	10	1397	24	635	229	N/A	5	Both Sides
IRP-48LH-HD	1245	165	102	71	376	305	127	25	76	10	10	1321	24	635	N/A	356	4	Left
IRP-48RH-HD	1245	165	102	71	376	305	127	25	76	10	10	1321	24	635	N/A	356	4	Right
RP-42EX-HD	1092	165	102	71	267	N/A	N/A	N/A	N/A	10	N/A	1092	24	N/A	N/A	N/A	4	No Curve
RP-48EX-HD	1207	165	102	71	267	N/A	N/A	N/A	N/A	10	N/A	1207	24	N/A	N/A	N/A	5	No Curve
RP-62EX-HD	1575	165	102	122	267	N/A	N/A	N/A	N/A	10	N/A	1575	24	N/A	N/A	N/A	6	No Curve

NOTE: Use 19 mm size Wedge Anchors (not included)

## Space-Saving Rack Protector Equipment Considerations

- Measure overall length of area that is to be protected.
- Measure the size of rack foot plates and clear dimensions between the foot plates.
- Is this a single or double end application? (The exposure to traffic is the key factor.)
- Placing protection equipment as close as possible and still provide an adequate barrier in front of what you're protecting to achieve proper installation.

Protection equipment is used anywhere throughout the plant and warehouse. Key areas for these types of equipment are rack and shelving ends. The cost of the protection equipment is minimal when considering what is being protected and the cost to repair or replace it if it is damaged.



# AREAS TO INSTALL SPACE SAVING RACK PROTECTORS



**Double End Space Saving Rack Protectors**

**Size Comparison**

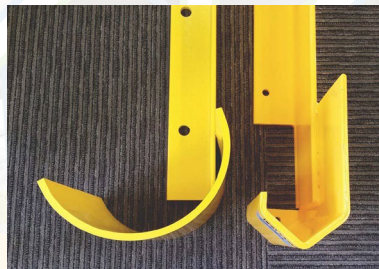
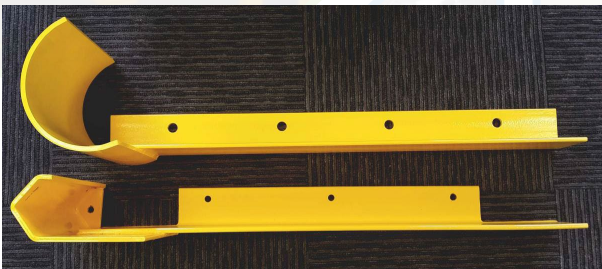

**Left Hand Side**



**Right Hand Side**



# STEEL GUIDE ANGLE

Guide Angles protect your warehouse racks aisles and corridor walls from dangerous and costly forklift impacts.

Guide Angles are also useful as pallet stops or in aisleways for guiding order pickers.

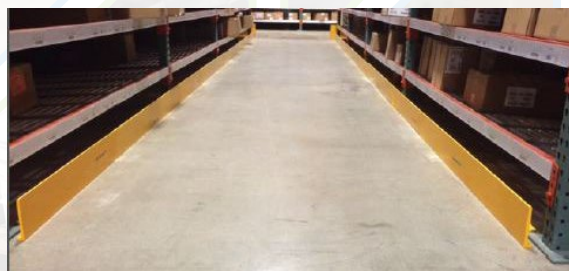

## FEATURES

- Increase the life of your racking without costly replacement of damaged column legs
- Increased safety for your workers- prevent direct impacts from rack columns saving from possible rack dislodgment and or inventory damage
- and falls.
- Stocked in 3048 mm lengths
- Powder coated in yellow for high visibility
- Heavy Duty (10 mm) and Medium Duty (6) thickness.

## STEEL GUIDE ANGLE SPECIFICATIONS

Part	Length (mm)	Angle Dims (mm)	Anchor Size (mm)	Material Thickness (mm)	Number of Anchors
GA-10	3048	152 X 102	19	10	5
GA-10-MD	3048	152 X 102	19	6	5

# POST PROTECTORS

Post Protectors are designed as an economical way to protect racking from manually transferred materials. Installation is easy and can be used in many rack protecting applications.

Bright yellow powder coat paint makes the post protector easily seen.



## FEATURES

- Post Protectors help prevent damage to rack uprights, shelving uprights, partitions and many other factory and warehouse structures
- These heavy steel protectors provide a low cost method of reducing damage to expensive equipment and protecting personnel from falling rack structures hit by moving vehicles
- Post Protectors wrap around the 76 mm column face vertical member to be protected, closely fitting, yet protecting, the upright from damage from collisions with forklifts or other moving vehicles
- These heavy duty 5 mm thick steel protectors are easily mounted by securing to the concrete floor using four 12 mm diameter wedge anchors (supplied as optional purchase)
- A variety of standard heights are available (304.8 mm, 457 mm & 610 mm) with custom heights and openings also available on special order
- Post Protectors are painted in safety yellow hard glossy finish for a durable attractive appearance
- Custom sizes are available, including seismic applications.





# POST PROTECTORS SPECIFICATIONS

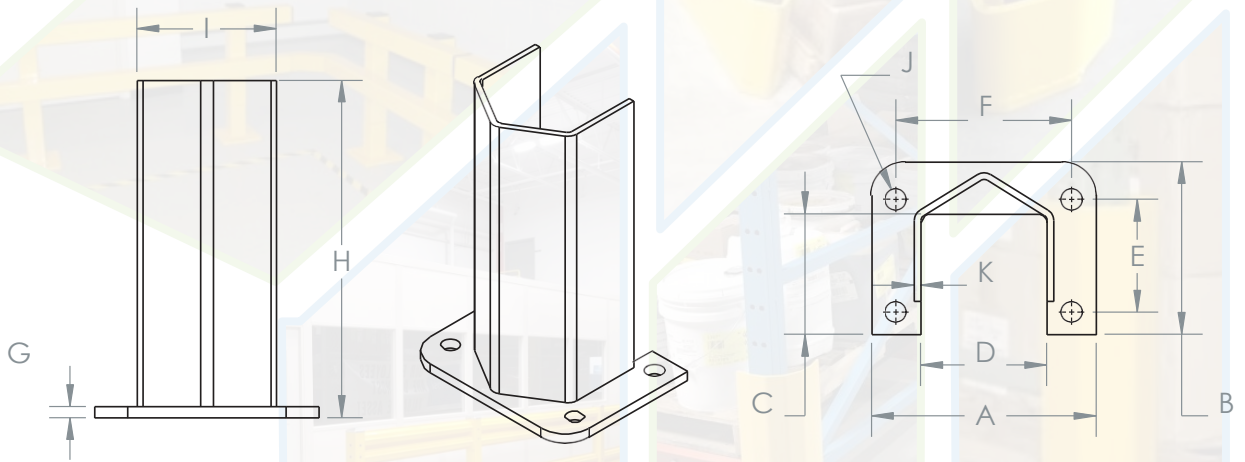

Model	A Overall Width (mm)	B Overall Length (mm)	C Inside Length (mm)	D Inside Width (mm)	E Side Hole to Hole (mm)	F Front Hole to Hole (mm)	G Base Plate Thickness (mm)	H Overall Height (mm)	I Guard Width (mm)	J Hole Diameter (mm)	K Guard Thickness (mm)
P12	203	156	114	114	102	159	6	305	127	19	5
P18	203	156	114	114	102	159	6	457	127	19	5
P24	203	156	114	114	102	159	6	610	127	19	5
P12-6	241	156	114	152	102	197	6	305	165	19	5
P18-6	241	156	114	152	102	197	6	457	165	19	5
P24-6	241	156	114	152	102	197	6	610	165	19	5
P12-8	305	156	114	216	102	260	6	305	229	19	5
P18-8	305	156	114	216	102	260	6	457	229	19	5
P24-8	305	156	114	216	102	260	6	610	229	19	5

## Post Protector Selection Tips

- Measure across foot plate of rack application
- Select desired width (refer to column D) that best suits foot plate
- Select desired height (refer to column H) for needed protection



# AREAS TO INSTALL POST PROTECTOR



# UNIVERSAL POST PROTECTORS

Universal Post Protectors are designed to fit on any type of warehouse rack baseplate, but is specifically designed for seismic baseplates. This raised guard allows you to install over the top of the baseplate instead of bolting a wide guard

surrounding the entire baseplate which can eat up a lot of floor space.

Universal Post Protectors are designed to withstand impact from forklifts along with any other machine traffic throughout your facility.



## FEATURES

- Protect the most vulnerable part of your rack leg
- Specifically designed for oversized footplates reduces the overall width of the guard
- Saves floor space by installing over seismic plates
- 2 anchor design speeds up installs
- Low profile design
- Powder coated in yellow for high visibility
- Custom sizes available

Part Number	Material Thickness	Height (mm)	Inside Width (mm)	Anchor Size (mm)	Number of Anchors	Weight (kg)
P12-3R	7 Gauge	305	305	12	2	4
P12-4R	7 Gauge	305	305	12	2	4

# V-NOSE GUARDS POST PROTECTORS

V-Nose Guards provide superior protection to the posts in your racking aisles. They are designed to withstand impact from forklifts along with any other machine traffic throughout your facility.

It is important to preserve the integrity of the racking systems where inventory is stored. By installing V-Nose Guards you gain invaluable benefits.

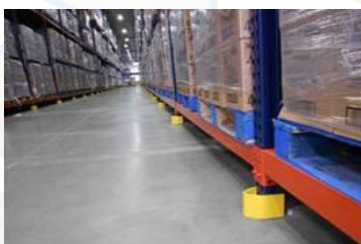
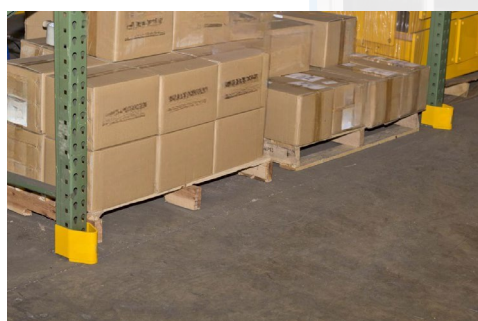

## FEATURES

- Protect the most vulnerable part of your rack leg
- Reinforces the rack upright
- 10 mm Thickness Heavy Duty
- Hidden anchor eliminates snagging
- Low profile design
- Powder coated in yellow for high visibility
- Two standards sizes: 102 mm height with 102 mm inside dimension or 83 mm inside clearance
- Custom sizes available

Part Number	Material Thickness (mm)	Height (mm)	Inside Width (mm)	Anchor Size (mm)	Number of Anchors	Weight (kg)
SP3-HD	10	102	83	12	1	3
SP4-HD	10	102	83	12	1	3

# STEEL BOLT ON PROTECTORS

Steel Bolt on Protectors as a space-saving deflector that keeps the floor clear and enables you to install the protection at the exact height you need.

No need for drilling concrete to anchor the guards. The bolts fit into the accessory bolt holes on your rack uprights.



## FEATURES

- Reinforces rack uprights with more steel
- High Visibility yellow powder coating
- Doesn't require floor anchoring
- Slim profile

Model	Height (mm)	Number of Mounting Holes	Shipping Weight (kg)	Material Thickness (mm)	Inside Clearance (mm)	Mounting Hole Diameter (mm)
BP-12	305	2 BOLT HOLES	3.6	4	83	8
BP-24	610	3 BOLT HOLES	5.5	4	83	8

# CORNER COLUMN PROTECTORS

Corner Column Protectors are designed as an economical way to protect racking from manually transferred materials. Installation is easy and can be used in

many rack protecting applications.

Handle It yellow powder-coated paint provides high visibility.



## FEATURES

- Corner Column Protectors help prevent damage to rack uprights, shelving uprights, partitions, and many other factory and warehouse structures.
- Wrap around the vertical member to be protected, closely fitting, yet protecting, the upright from damage.
- These heavy duty 6 mm thick steel protectors are easily mounted by securing to the concrete floor using three 12 mm diameter wedge anchors (sold separately)
- These heavy steel protectors provide a low cost method of reducing damage to expensive equipment and protecting personnel from falling rack structures hit by moving machinery.
- 610 mm, 457 mm & 305 mm standard heights are available with custom heights by special order.
- Corner Column Protectors are painted in safety yellow with a hard powder coat finish for a durable and attractive appearance.



# CORNER COLUMN PROTECTOR SPECIFICATIONS

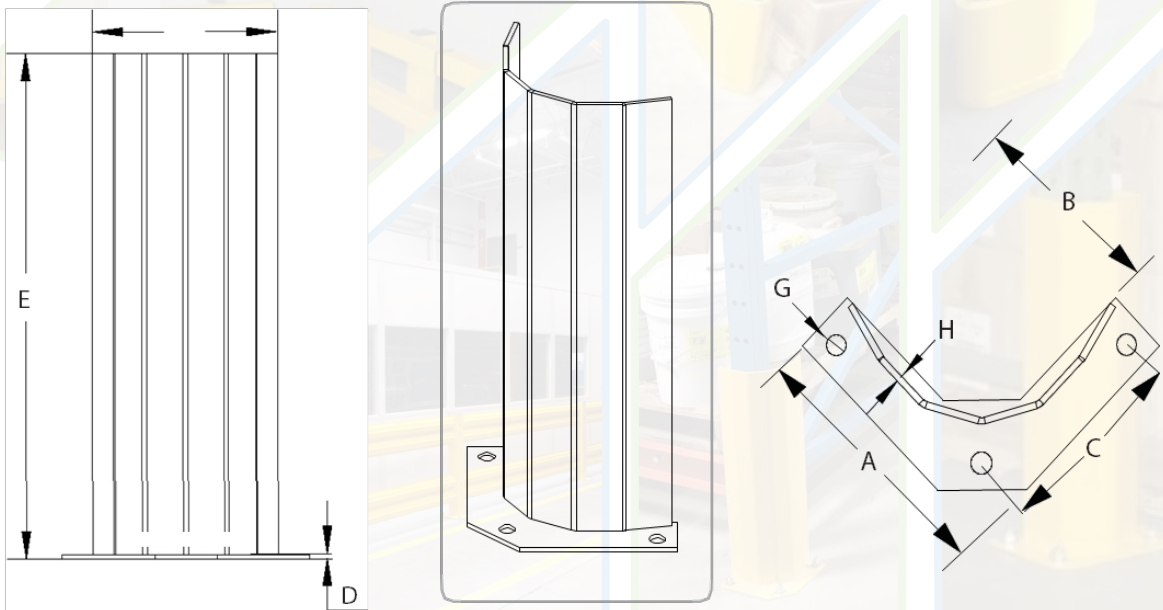

Part	A Base Plate L & W (mm)	B Inside Width (mm)	C Hole to Hole (mm)	D Base Plate Thickness (mm)	E Overall Height (mm)	F Guard Width (mm)	G Anchor Hole Diameter (mm)	H Guard Thickness (mm)
CCP12	203	152	146	6	305	165	12	6
CCP18	203	152	146	6	457	165	12	6
CCP24	203	152	146	6	610	165	12	6

## Corner Column Protector Selection Tips

- Select desired height (refer to column E)
- Protection equipment should fit as close as possible
- while still providing an adequate barrier in front of
- what is being protected

# AREAS TO INSTALL CORNER COLUMN PROTECTOR





# SHALLOW PROFILE COLUMN GUARDS

Shallow Profile Column guards offer in aisle rack post protection without taking up a large footprint of your aisle.

The guard is designed to deflect impacts from forklifts, pallet jacks, and pallets while they are being moved in and out of the rack bays.



## FEATURES

- Post Protectors help prevent damage to rack uprights, shelving uprights, partitions, and many other factory and warehouse structures
- These heavy steel protectors provide a low cost method of reducing damage to expensive equipment and protecting personnel from falling rack structures hit by moving machinery
- Post Protectors wrap around the 76 mm vertical member to be protected, - fitting- yet protecting the upright from damage from collisions with forklifts or other moving vehicles
- These heavy duty 6 mm thick steel protectors are easily mounted by securing to the concrete floor using two 12 mm diameter wedge anchors (supplied as optional purchase)
- A variety of standard heights are available with custom heights available on special order
- Post Protectors are painted in safety yellow with a hard glossy finish for a durable and attractive appearance



# CORNER COLUMN PROTECTORS SPECIFICATIONS

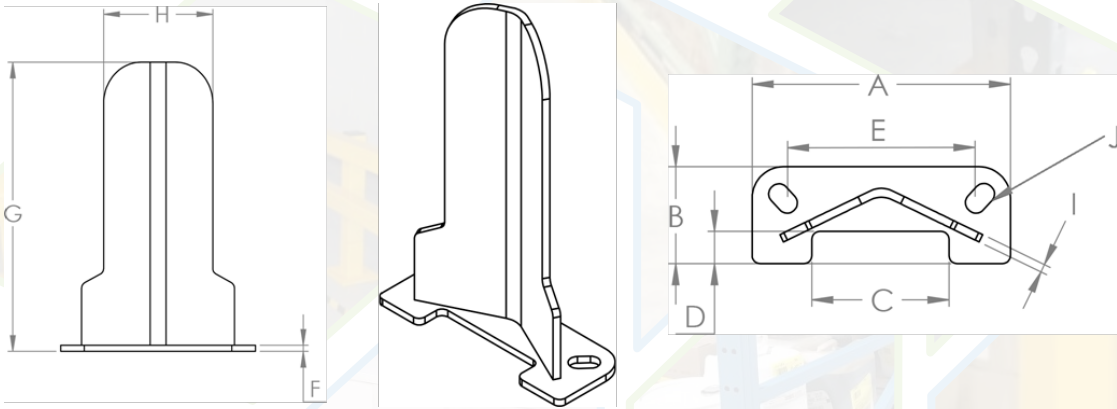

Part	A Overall Width (mm)	B Overall Length (mm)	C Inside Width (mm)	D Inside Length (mm)	E Hole To Hole Width (mm)	F Base Plate Thickness (mm)	G Overall Height (mm)	H Guard Width (mm)	I Guard Thickness (mm)	J Anchor Slot (mm)
P12-SP	203	76	114	25	159	6	305	114	6	16 x 25
P18-SP	203	76	114	25	159	6	457	114	6	16 x 25
P24-SP	203	76	114	25	159	6	610	114	6	16 x 25

## Shallow Profile Upright Post Protector Selection Tips

- Measure across foot plate of rack application.
- Select desired height (refer to column G).
- Do columns need to be offset on the base plate or is the column to be placed in the corner of the base plate?
- (Tight space conditions govern this decision.)





**MANUFACTURING FACILITY IN INDIA**



**MANIK**  
ENGINEERING PVT. LTD.

Plot No. 805, TTC Industrial Area,  
Kopar Khairane MIDC, Navi-Mumbai. Maharashtra, India.

Email: [sales@manikindia.com](mailto:sales@manikindia.com)

